



Amplificateur de casque à intégrer
Headphone amplifier to integrate





SOMMAIRE

⇒ Description	4
⇒ Synoptique	4
⇒ Face avant	5
⇒ Face arrière	6
⇒ Intégration	7
⇒ Caractéristiques	8

SUMMARY

⇒ English	9
-----------------	---

DESCRIPTION

Du fait de sa conception, cet amplificateur actif pour casque est très facilement intégrable sous le retour des mobiliers de studio, en s'affranchissant des découpes sur le plateau.

Il possède deux entrées gauche et droite symétriques, ainsi qu'une entrée d'ordre avec atténuation automatique du programme.

La connexion s'effectue par un câble RJ45 au standard de câblage international, celle-ci véhicule à la fois l'audio et l'alimentation.

L'extension vers d'autres modules PRF75A se fait par un simple câble RJ45 entre la sortie OUT du PRF75A amont vers l'entrée du suivant en aval. Le gain de temps en termes de câblage est particulièrement intéressant. Les trois modulations audio sont ainsi distribuées ainsi que l'alimentation.

La sortie casque peut se faire sur la face avant ainsi que sur le panneau arrière pour un éventuel déport.

Un switch MUTE fugitif très accessible sous le module, permet l'atténuation de la modulation audio sans retoucher au volume et sans enlever le casque.

SYNOPTIQUE

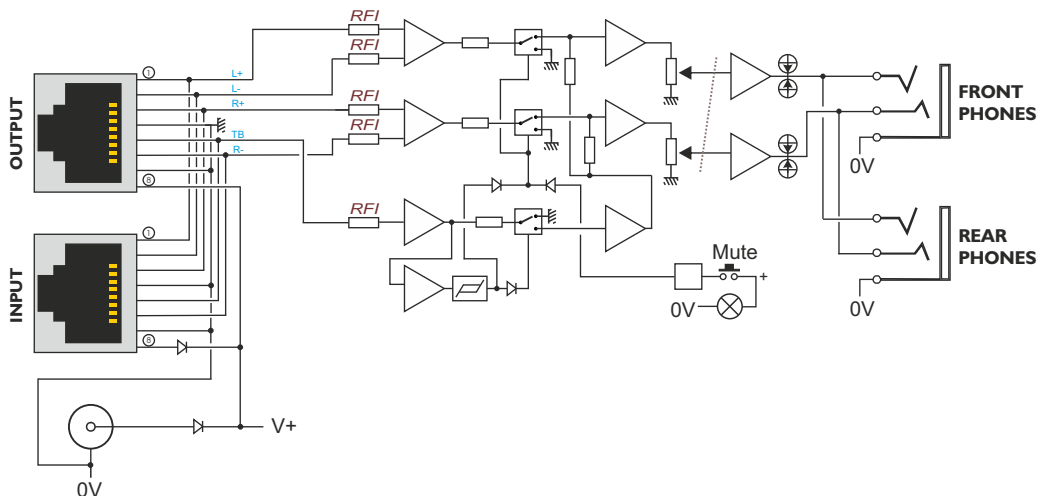

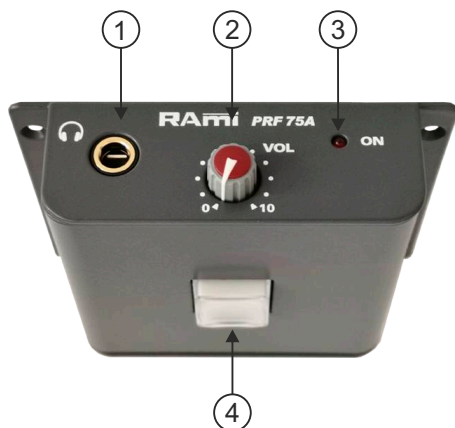

- 1 - Embase casque 6.35.
- 2 - Potentiomètre de volume.
- 3 - Témoin de mise sous tension.
- 4- Bouton fugitif de Mute. Il permet d'atténuer le volume du casque sans toucher au volume 2. Il permet aussi de tenir une conversation sans enlever le casque.

FACE ARRIERE

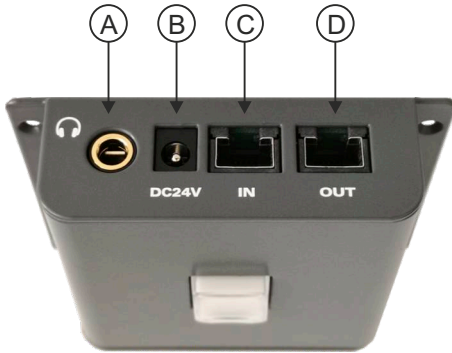

A - Embase casque 6.35.

B - Alimentation DC 24V.

C - Entrée RJ45.

D - Sortie RJ45. Elle permet l'extension vers un autre PRF75A.

- 1 ○ → IN + GAUCHE
- 2 ○ → IN - GAUCHE
- 3 ○ → IN + DROIT
- 4 ○ — GND/0V
- 5 ○ → IN TALKBACK
- 6 ○ → IN - DROIT
- 7 ○ — 0V
- 8 ○ → 24V

ENTREE RJ45

- 1 ○ → OUT + GAUCHE
- 2 ○ → OUT - GAUCHE
- 3 ○ → OUT + DROIT
- 4 ○ — GND/0V
- 5 ○ → OUT TALKBACK
- 6 ○ → OUT - DROIT
- 7 ○ — 0V
- 8 ○ → OUT 24V

SORTIE RJ45

Câblage avec plusieurs PRF75A

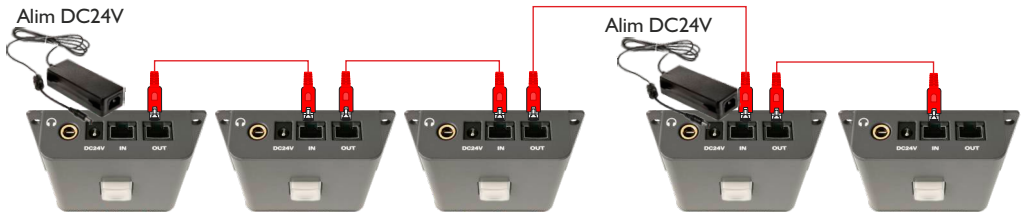

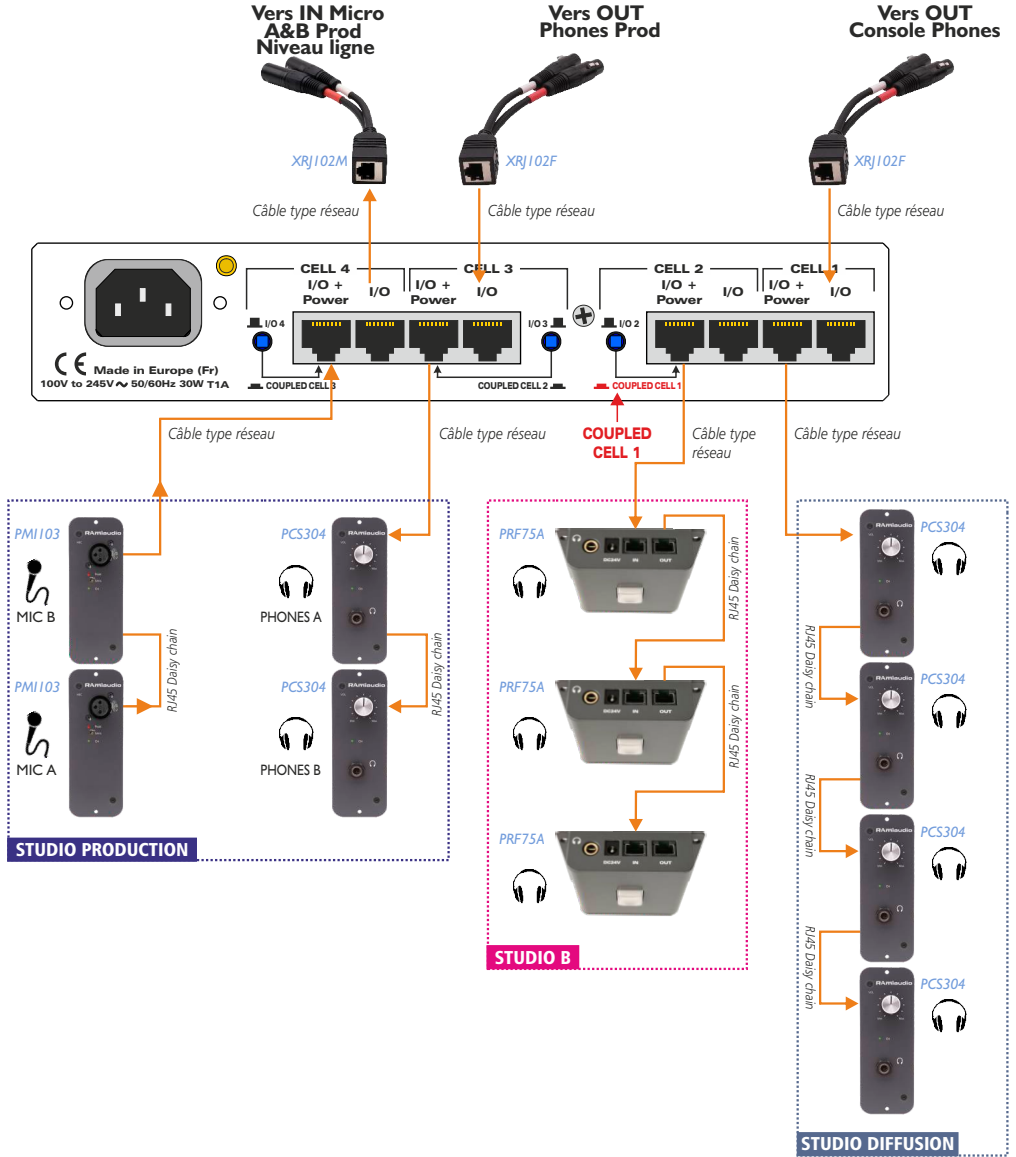

Dimensions du PRF75A

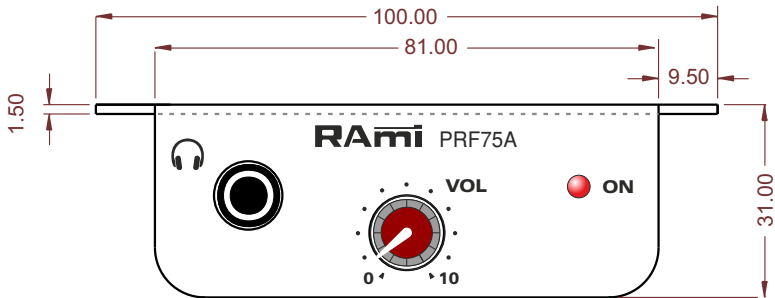
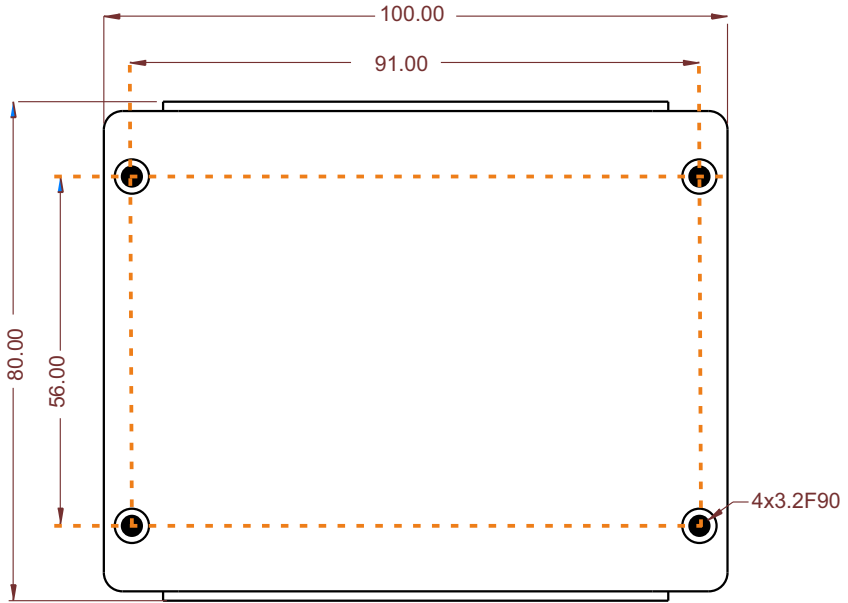



SUMMARY

⇒ Description	10
⇒ Block diagram	10
⇒ Front panel	11
⇒ Rear panel	12
⇒ Integration	13
⇒ Specifications	14

DESCRIPTION

Because of its design, this active headphone amplifier is very easily integrable under the return of studio furniture, freeing cutouts on the board.

It has two balanced left and right inputs, as well as a talkback input with automatic program attenuation.

The connection is made using an international standard RJ45 cable, which carries both audio and power. (otherwise called standard axia)

The extension to other PRF75A modules is via a single RJ45 cable between the "OUT" output of the first PRF75A to the "INPUT" of the next PRF75A, and so on. The saving of time in terms of wiring is particularly interesting. The three audio modulations are distributed as well as the power supply.

The headphone output can be done on the front as well as on the rear panel.

A fugitive MUTE switch very accessible under the module, allows the attenuation of the audio modulation without changing the volume and without removing the headphones.

BLOCK DIAGRAM

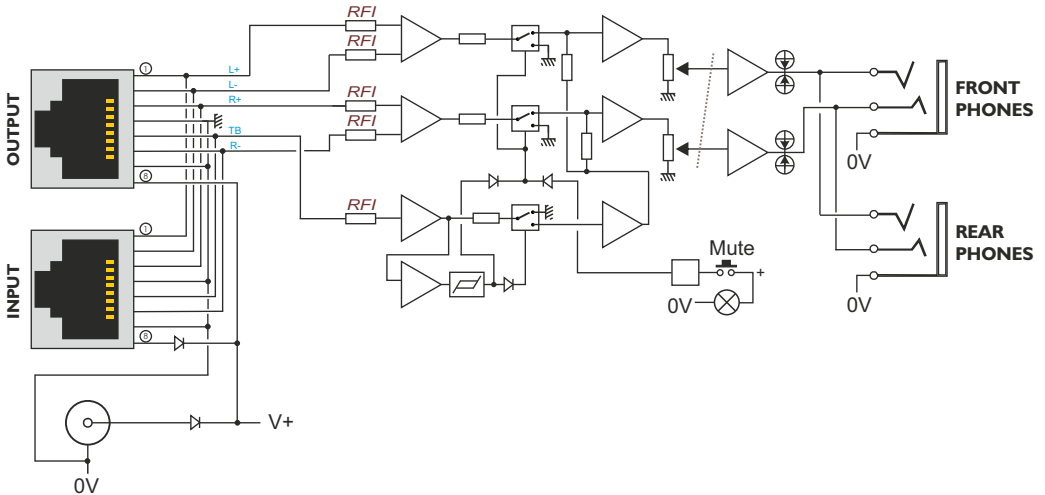

FRONT PANEL

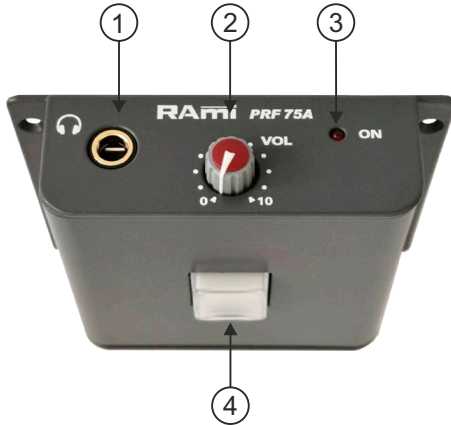

- 1 - Headphone socket 6.35mm.
- 2 - Volume potentiometer.
- 3 - Power-on indicator.
- 4 - Mute fugitive button. It allows to reduce the volume of the headphones without changing the volume 2. It also allows to hold a conversation without removing the headphones.

REAR PANEL

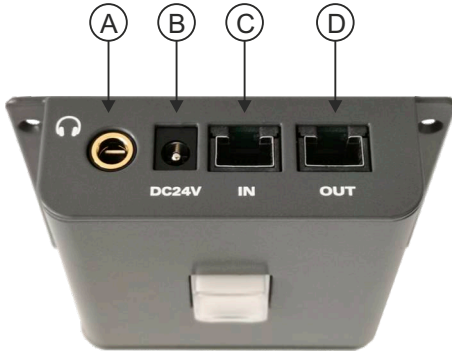

A - Headphone socket 6.35mm.

B - DC 24V power supply.

C - RJ45 input.

D - RJ45 output. It allows the extension to another PRF75A.

- 1 ○ ← Left IN +
- 2 ○ ← Left IN -
- 3 ○ → Right IN +
- 4 ○ — GND/0V
- 5 ○ ← TALKBACK IN
- 6 ○ → Right IN -
- 7 ○ — 0V
- 8 ○ ← 24V

RJ45 INPUT

- 1 ○ → Left OUT +
- 2 ○ → Left OUT -
- 3 ○ → Right OUT +
- 4 ○ — GND/0V
- 5 ○ → TALKBACK OUT
- 6 ○ → Right OUT -
- 7 ○ — 0V
- 8 ○ → OUT 24V

RJ45 OUTPUT

Wiring with multiple PRF75A

P. supply: DC24V

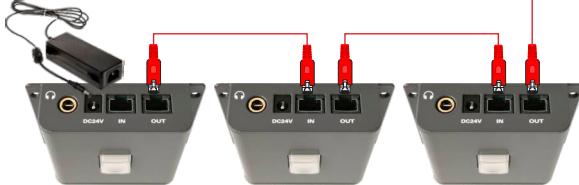

P. supply: DC24V

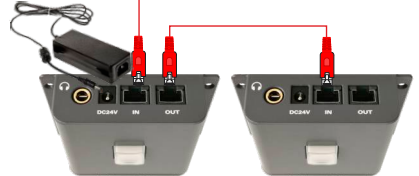

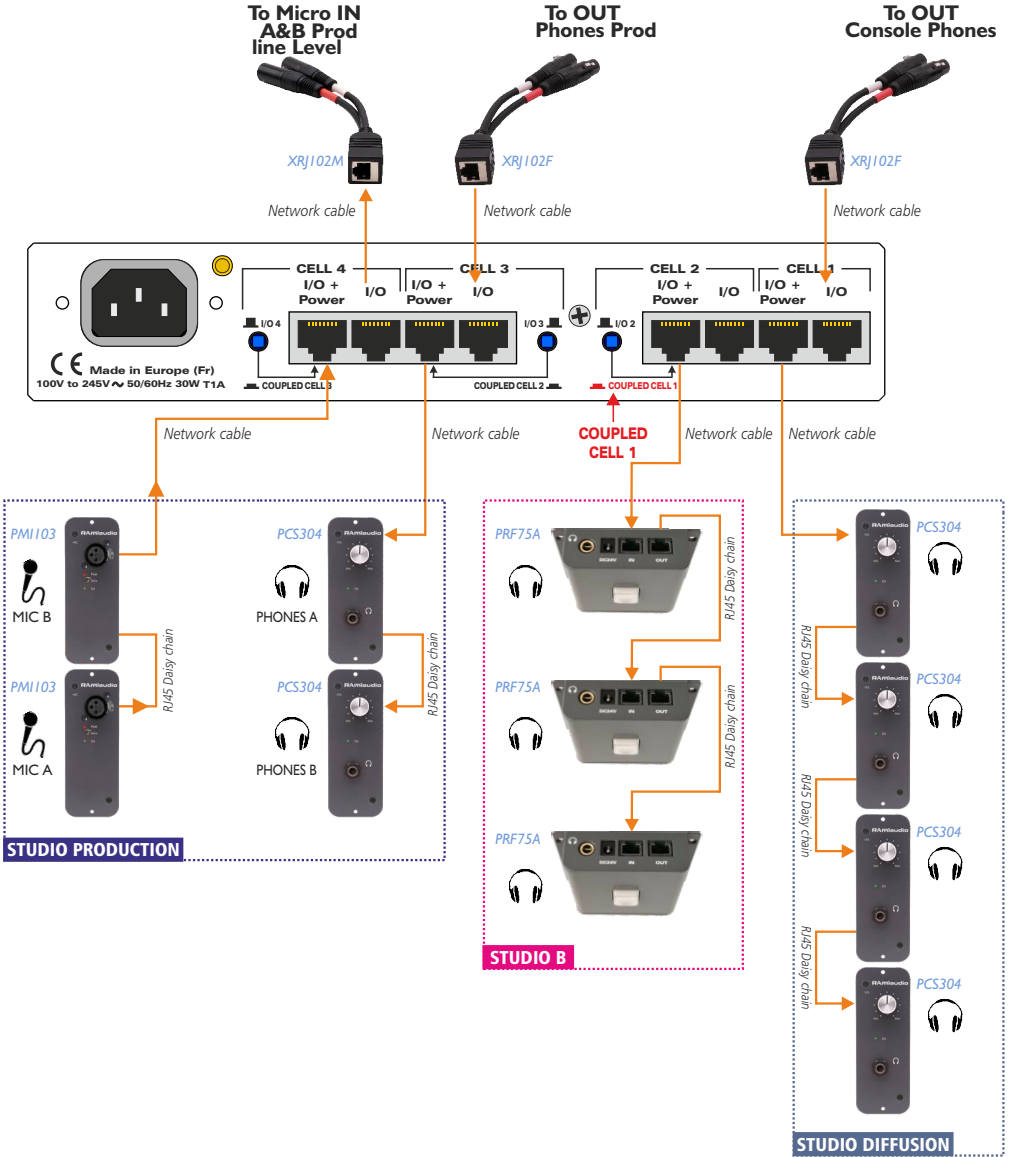

PRF75A Dimensions

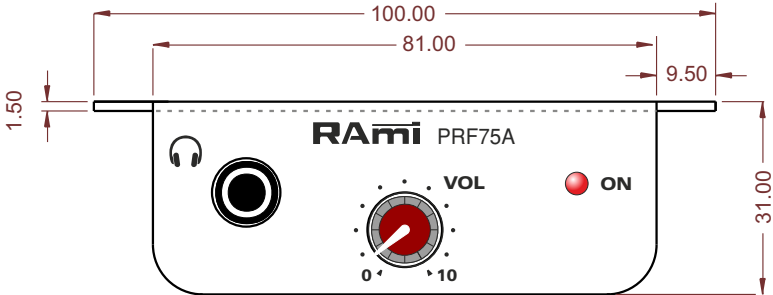
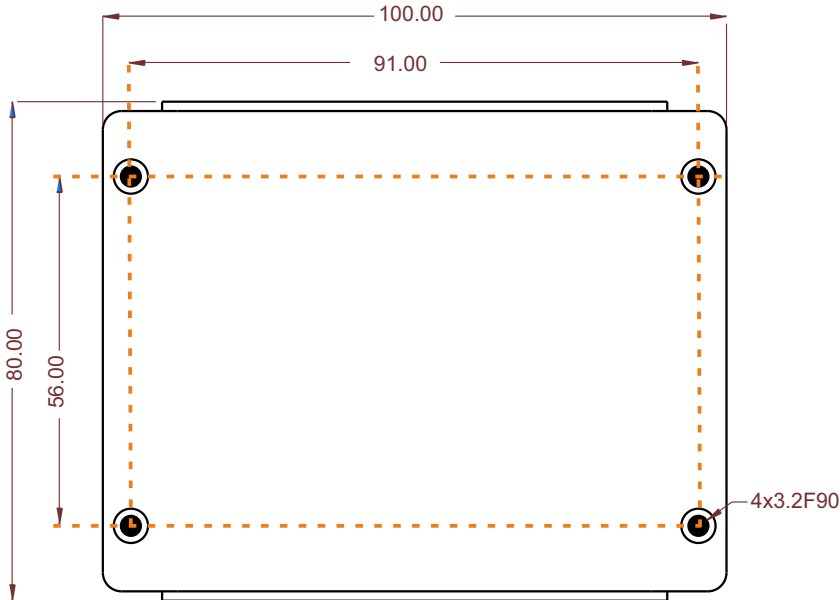

RAmi

**7 Rue Raoul Follereau
77600 BUSSY SAINT GEORGES - FRANCE**

Tél. : 33 (0)1 64 66 20 20

E-mail : rami@ramiaudio.com

www.ramiaudio.com